

The Peek Traffic TS2 NEMA Bus Interface Unit (BIU) is a rack mounted modular-by-function unit that allows easy adaptation to many applications. Its primary function is to interface the 24 VDC logic based inputs and outputs (I/O) to the Synchronous Data Link Control (SDLC) serial bus within the TS2 cabinets. The Controller Unit functionality in a Type 1, and some Type 2 configurations, is interfaced to the TS2 cabinet through the BIU(s). This functionality includes controlling all load switch outputs, detector inputs and resets, and functions previously accessed via TS1- A,B,C connectors and/or additional I/O (MSD).

The BIU utilizes a 32 bit processor and is in full compliance with NEMA TS2 Standards for the interface, power, environmental, electrical and physical hardware requirements. The BIU is powered by a separate 24 VDC power supply external to the Controller Unit. The front panel contains a handle for easy removal and insertion of the unit, power on and transmit status indicators, a 15 pin female Port 1 connector and an optional RS232 connector. The BIU interfaces to the Port 1 facilities termination panel through a 15 pin metal shell D sub miniature type connector that is equipped with latching blocks. Connection to the Terminal and Facilities (TF) backpanel or card rack is provided by a 64 pin DIN 41612 type B series connector.

The TS2 Controller Unit communicates through the BIUs based on the digital addressing of each BIU. Each BIU shall be capable of having their logical position and subsequent cabinet functions, assignable through specific address select inputs. This cabinet function flexibility allows for cabinet expansion, enhances reliability and provides a standard interface with Peek Traffic or other manufacturers' TS2 cabinets.

- Full compliance with NEMA TS2-2003
- Port 1 RS-485 SDLC interface
- Facilitates high speed data exchange between controller, cabinet, detector racks and malfunction management unit
- Performs conversion for 24VDC I/O logic signals to serial bus
- Rack mounted for modularity and interchangeability
- BIU address programmable via Terminal and Facilities
- Peek BIU-S – This upgrade includes an extra RS232 Port for mapping System detector inputs (Ports 33-64) from an external serial source

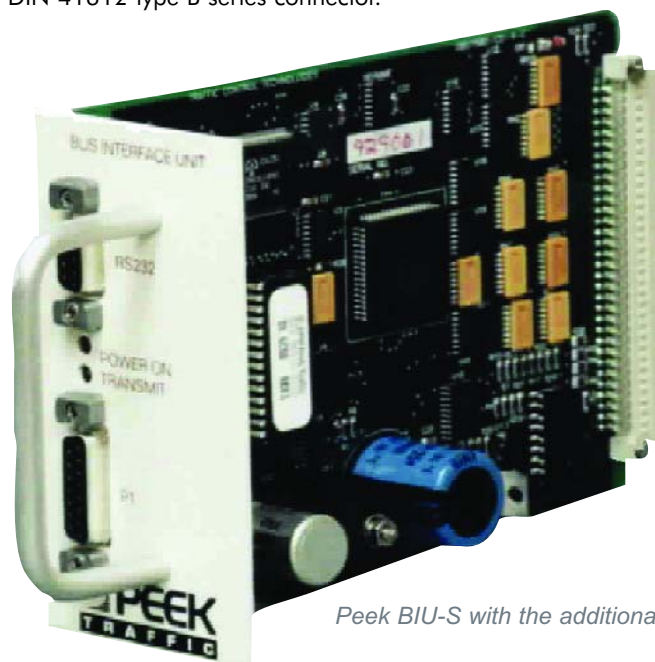

Peek BIU-S with the additional RS232 Port for Detector Input mapping

Features

The Port 1 15 Pin D Connector meets the requirements for the physical layer and the protocol for the full duplex SDLC serial data bus and is in full compliance with Sections 3.3.1 and 8.6.2 of the NEMA TS2 -2003 Standard.

The BIU card rack connector is a 64 pin DIN 41612 type B series connector with pin assignments as specified in Section 8.6.3.1 of the NEMA TS2 Standard.

Address select inputs shall define the logical position of each BIU. The BIU positions 1-8 are designated for Terminals and Facilities (TF) and BIU positions 9 -16 are designated for Detector Racks. Currently up to 16 detector channels are assignable per BIU allowing up to a maximum of 64 detector channels. BIU positions 5-8 and 13-16 are reserved for future expansion requirements for TS2 or reserved for manufacturer specific functions.

Specifications

Signal Inputs Each BIU provides eight DC inputs, four opto isolated inputs, 24 assignable input/output pins, 15 DC outputs and four address select inputs.

Isolated Inputs Four optically isolated inputs for use with pedestrian detector inputs or remote hardwired interconnect inputs. The opto inputs are intended for direct connection to 12VAC from the cabinet power supply when used with pedestrian pushbuttons. 120VAC interconnect inputs are interfaced through external 27K Ohm, 1 Watt resistors.

Dimensions 4.5" H x 2.34" W x 6.5" D
(114.3 mm H x 59.44 mm W x 165.1 mm D)

Temperature -30°F to +165°F
(-34°C to +74°C)

Weight 0.525 lb. (0.283 kg)

Power 18 to 30 VDC, 200 mA

Ordering Information

<u>Description</u>	<u>Model Number</u>
Peek Bus Interface Unit	BIU100
Peek Bus Interface Unit-Serial Input	BIU100S

BIU-S External Inputs via Serial Connector

The 'S' option for the Peek Bus Interface Unit adds a second serial port to the front panel of the BIU, a 9 pin D-sub standard RS232 port. The purpose of this second port is to allow input of data from an external input aggregator, such as a detector hub, to be routed to the TS2 Type 1 traffic controller. Depending on the mapping defined in the BIU firmware, these inputs can be used for a wide range of purposes. One currently available mapping can handle the serial signal from an ISS Spider™ RTMS® detector hub, mapping the hub's 32 outputs to the BIU's Detector 33 through 64 inputs. This is an easy and efficient way to bring other types of detection, particularly mid-block volume data, into a TS2 controller for Adaptive Control scenarios.

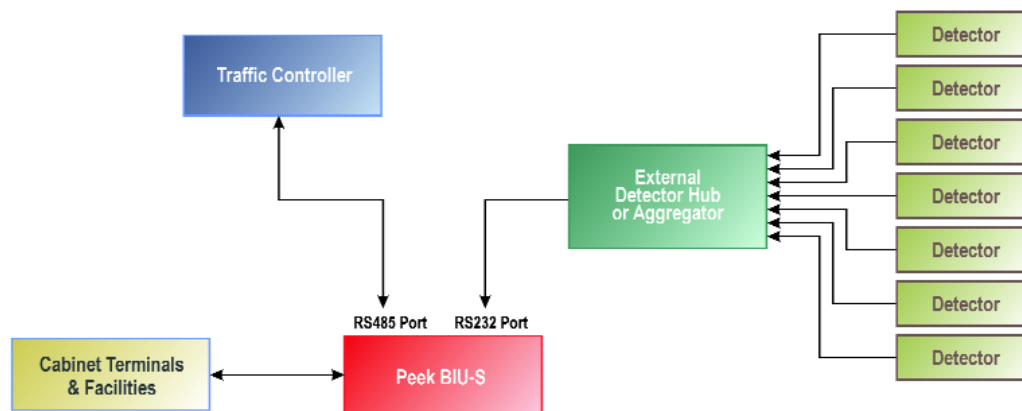

A Signal Group Company
Peek Traffic Corporation
2906 Corporate Way, Palmetto, FL 34221
Phone: (941) 845-1200 • Fax: (941) 365-0837

